

**Premium
High-
Performance
Punches**

VERSA [®] *plus*



Global leader in
quality metal fabrication
and stamping tools

a MISUMI Group Company

www.daytonlamina.com



TEL. 81 8354 8910
www.acatmexicana.com

If optimum performance

is a MUST,
this may be
the only
punch
you'll ever
need.



Product Applications

VersaPlus® Jektole®, Regular, and Straight Punches are a premium line of precision, high-performance products that offer a full range of features and benefits to users in industries where higher-than-normal production runs occur—and where optimum performance is a MUST.

Standard features on all Dayton VersaPlus® punch products include precision concentricity between the point and the shank, resulting in better punch and die alignment. VersaPlus® products give you more standard features, increased wear resistance, less sharpening time, longer die runs, less downtime, lower maintenance costs, and exceptional value for your stamping dollar.

Dayton's VersaPlus® premium product line includes: **Jektole® Punches (slug ejection punches); Regular Punches; Straight Punches; and Locking Devices.** Standard sizes and standard alterations are shown in this catalog within individual product sections.

Features/Benefits

All VersaPlus® punch products utilize a unique combination of surface treatments to create a longer-lasting, lower maintenance, premium product.

Regular VersaPlus® punches provide three times better alignment than other major brands; offer longer tool life; and can significantly improve finished part quality.



Ordering Information

Each catalog page contains detailed instructions on how to order specific Dayton VersaPlus® products. Individual drawings show product shape, dimensions, tolerances, and concentricity. When ordering, you are asked to specify quantity, type, shank and length codes (for example), and other applicable data.

In the example below, the type specified is "VPRP." "V" stands for Versatile, "P" stands for punch, "R" stands for rectangle, and "P" stands for Plus. 37 is the press-fit diameter, which is coded by the first two digits of the decimal equivalent (.375). The point length (L₁) is 050, which is ½" or .50". The overall length (L) is 375, which is 3¾" or 3.750". Finally, P.1875 and W.1325 represent the point or hole size dimension.

HOW TO ORDER

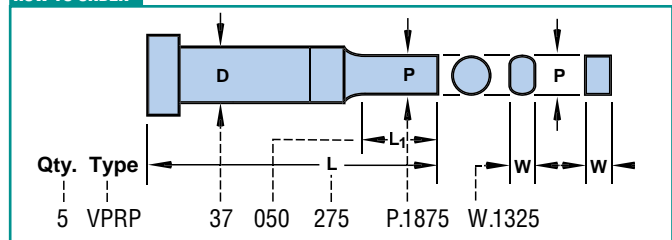

Standard Alterations

Punches and die buttons are available in sizes other than those listed in the catalog.

When ordering, you are asked to specify different designations for various non-standard dimensions. For example, if the P & W dimensions are smaller than standard, an "X" is placed in front of the P or W dimensions, e.g., "XP" and "XW." If the point length is longer than standard, designate "XBR" for the point length. See the foldout tabs in the individual product sections for these and other special order designations.

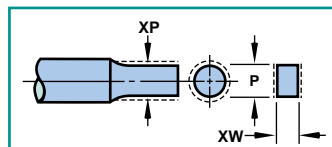

Punches

Standard Shapes

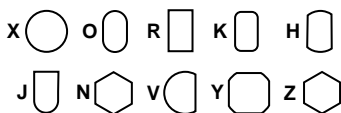

VJ_P Jektol®

Round/Shape



4, 5

VP_P Regular

Round/Shape



6, 7

VPTP/VPAP Pilots

8-11



VYXP/VUXP Straight

Jektol®/Regular



12, 13

Miscellaneous/Other

Classified Shapes

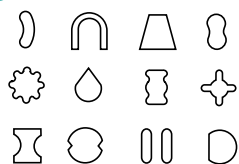

14, 15

Locking Devices

Key Flats/Dowel Slots

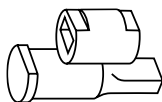

16, 17

Jektol® Data

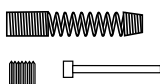

18

Shear Angles

19

Product Designation

Each page contains detailed instructions on how to order specific Dayton VersaPlus® products. In addition, use the following chart to define the product as a part number.

Example:

VPRP	Line Product Shape	V for Versatile P for Punch (Regular) R for Rectangle P for Plus
37	Press-Fit Dia. D (shank diameter)	Coded by the first 2 digits of decimal equivalent (.375)
050	Point Length L₁	Coded by three-digit decimal equivalent (050 = .50")
375	Overall Length L	Coded by three-digit decimal equivalent (375 = 3.75")
VPRP	Product Series	
37 - 050 - 375	Length	P.1875, W.1325
Type	Catalog Number	Dimensions As Specified

Diameter (D) is shown on the order as a two- or three-digit code. To convert the shank diameter to the appropriate code, use the following chart.

Code	D	Code	D	Code	D
12	.1250	37	.3750	75	.7500
18	.1875	43	.4375	87	.8750
25	.2500	50	.5000	100	1.0000
31	.3125	62	.6250		

Classified Shapes

Classified shapes (83 common shapes, no detailing required) are available on all punches, die buttons, and guide bushings as indicated in this catalog. See pp. 14, 15 for more information and special instructions. Also, see individual product pages and pp. 16, 17 for additional information on orientation and views.

Clearance

Normal grinding methods produce:

- .007 max fillet on the punch—matching corner shape on the die button.
- .007 max fillet on the die button—matching corner shape on the punch.

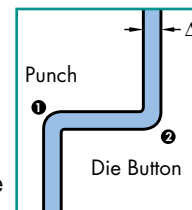

Sharp corners will be broken to minimize wear.

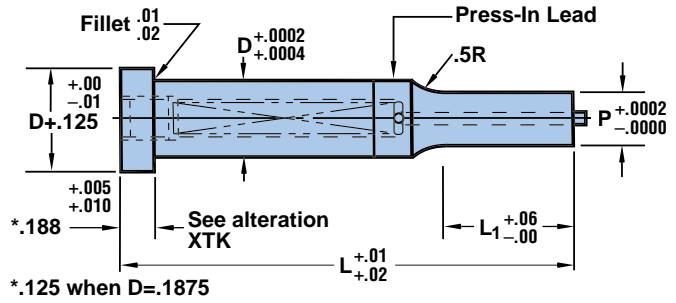

Material
 All heads are drawn to RC 40-55.
 Proprietary high-performance material and treatment
 P&W Tolerance $+ .0002$ to $- .0000$ P to D $.0003$ ©

HOW TO ORDER

Specify:	Qty.	Type	D Code	Point Length L ₁	Overall Length L	P (or P&W) Dimension
Example:	2	VJXP	37	075	275	P.250

FDS
 FIRM DELIVERY SCHEDULE
 Round & Std. Shapes - 4 Days
 Classified Shapes - 5 Days

Shank D	Code	Point Lgth. L ₁	Round		Shape			L														
			Min. XP	Range P	Min. XW	Min. W	Max. P/G	1.75	2.00	2.25	2.50	2.75	3.00	3.25	3.50	3.75	4.00	4.25	4.50			
.1875	18	.50	.050	.062-.1874	.062	.062	.1875															
.2500	25		.080	.093-.2499	.080	.093	.2500															
.3125	31		.115	.125-.3124	.115	.125	.3125															
.3750	37		.158	.187-.3749	.158	.187	.3750															
.4375	43		.158	.187-.4374	.158	.187	.4375															
.5000	50		.158	.225-.4999	.158	.250	.5000	050175	050200	050225	050250	050275	050300	050325	050350	050375	050400					
.6250	62		.235	.310-.6249	.235	.282	.6250												050425	050450		
.7500	75		.300	.390-.7499	.235	.312	.7500															
.8750	87		.350	.440-.8749	.235	.343	.8750															
1.0000	100		.400	.485-.9999	.235	.375	1.0000															
.1875	18	.75	.058	.062-.1874	.093	.093	.1875															
.2500	25		.080	.093-.2499	.093	.093	.2500															
.3125	31		.115	.125-.3124	.115	.125	.3125															
.3750	37		.158	.187-.3749	.158	.187	.3750															
.4375	43		.158	.187-.4374	.158	.187	.4375															
.5000	50		.158	.225-.4999	.158	.250	.5000															
.6250	62		.235	.310-.6249	.235	.282	.6250															
.7500	75		.300	.390-.7499	.235	.312	.7500															
.8750	87		.350	.440-.8749	.235	.343	.8750															
1.0000	100		.400	.485-.9999	.235	.375	1.0000															
.2500	25	1.00	.080	.093-.2499	.093	.093	.2500															
.3125	31		.115	.125-.3124	.115	.125	.3125															
.3750	37		.158	.187-.3749	.158	.187	.3750															
.4375	43		.158	.187-.4374	.158	.187	.4375															
.5000	50		.158	.225-.4999	.158	.250	.5000															
.6250	62		.235	.310-.6249	.235	.282	.6250															
.7500	75		.300	.390-.7499	.235	.312	.7500															
.8750	87		.350	.440-.8749	.235	.343	.8750															
1.0000	100		.400	.485-.9999	.235	.375	1.0000															
.3125	31		1.25	.115	.125-.3124	.115	.125	.3125														
.3750	37	.158		.187-.3749	.158	.187	.3750															
.4375	43	.158		.187-.4374	.158	.187	.4375															
.5000	50	.158		.225-.4999	.158	.250	.5000															
.6250	62	.235		.310-.6249	.235	.282	.6250															
.7500	75	.300		.390-.7499	.235	.312	.7500															
.8750	87	.350		.440-.8749	.235	.343	.8750															
1.0000	100	.400		.485-.9999	.235	.375	1.0000															

*See p. 18 for additional information.

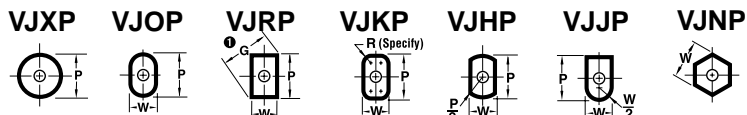

1 Check your P&W dimensions to be certain the diagonal G does not exceed the maximum shown.

2 Centerline to flat minimum = .025 for J2, .040 for J3, .058 for J4, .079 for J6, .118 for J9

Note: Sharp corners will be broken to minimize wear.

Note: The standard location of a key flat is at 0°. See p.17 for more information on flats and dowel slots.

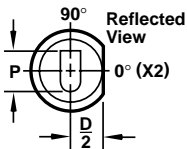

Code	L								* Jektol® Group
	4.75	5.00	5.25	5.50	5.75	6.00	6.25	6.50	
18									J2
25									J3
31									J4
37									J6
43									J6
50	050475	050500	050525	050550	050575	050600			J6
62							050625	050650	J9
75									J9
87									J9
100									J9
18									J2
25									J3
31									J4
37									J6
43									J6
50	075475	075500	075525	075550	075575	075600	075625	075650	J6
62									J9
75									J9
87									J9
100									J9
25									J3
31									J4
37									J6
43									J6
50	100475	100500	100525	100550	100575	100600	100625	100650	J6
62									J9
75									J9
87									J9
100									J9
31									J4
37									J6
43									J6
50	125475	125500	125525	125550	125575	125600	125625	125650	J6
62									J9
75									J9
87									J9
100									J9

Standard Alterations

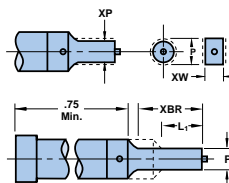

XP, XW P & W Dimensions Smaller than Standard

XBR Point Length Longer than Standard

Point Length	.000	.501- .750	.751- 1.000	1.001- 1.250	1.251- 1.500	.000	.501- .750	.751- 1.000	1.001- 1.250	1.251- 1.500	* Jektol® Group
Code	Min. P (Rounds)					Min. W (Shapes)					
18	.050	.058				.062	.093				J2
25	.080	.080	.080			.080	.093	.093			J3
31	.115	.115	.115	.115	.115	.115	.115	.115	.115	.115	J4
37	.158	.158	.158	.158	.158	.158	.158	.158	.158	.158	J6
43	.158	.158	.158	.158	.158	.158	.158	.158	.158	.158	J6
50	.158	.158	.158	.158	.158	.158	.158	.158	.158	.158	J6
62	.235	.235	.235	.235	.235	.235	.235	.235	.235	.235	J9
75	.300	.300	.300	.300	.300	.235	.235	.235	.235	.235	J9
87	.350	.350	.350	.350	.350	.235	.235	.235	.235	.235	J9
100	.400	.400	.400	.400	.400	.235	.235	.235	.235	.235	J9

*See p. 14 for additional information.

XD Reduced Shank Diameter

Head diameter does not change with body diameter.

Shank Dia.	18	25	31	37	43	50	62	75	87	100
Min. XD	.172	.218	.282	.344	.376	.438	.562	.688	.813	.938

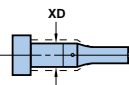

XL Overall Length Shortened (1.00 min.)
Stock removal from point end. L₁ length is maintained.

LL Precision Overall Length
Same as XL except overall length is held to ±.001.

XT Thinner Head than Standard
Stock removal from head end which shortens overall length.

TT Precision Head Thickness
Same as XT except head thickness tolerance is held to ±.0005.

XH Reduced Head Diameter
Minimum head equals D +.000 - .001.

XTK Kommercial Head Thickness

Shank Dia. D	18	25	31	37	43	50	62	75	87	100
Thickness T	.125	.125	.125	.188	.188	.188	.250	.250	.250	.250

XK No Side Hole
For air ejection. No cost.

XJ Smaller Jektol Components
See p. 18.

SBR Straight Before Radius

To determine Length of Radius Blend (LRB)

1. Calculate (D-P)/2.
2. Find (D-P)/2 value on left side of chart.
3. Follow line over to intersection point on radius blend line.
4. Read LRB value on bottom of chart.

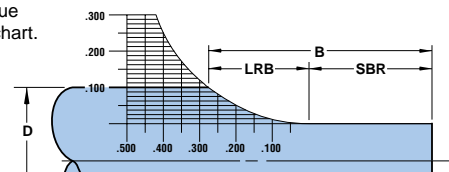

Example:
D=.375
P=.175

$$(D-P)/2 = (.375 - .175)/2 = .100$$

Following the .100 line on chart over the radius blend line shows the LRB to be approximately .300.



Material
 All heads are drawn to RC 40-55.
 Proprietary high-performance material and treatment
 P&W Tolerance $\begin{matrix} +.0002 \\ -.0000 \end{matrix}$ P to D $\begin{matrix} .0003 \\ \text{Ⓢ} \end{matrix}$

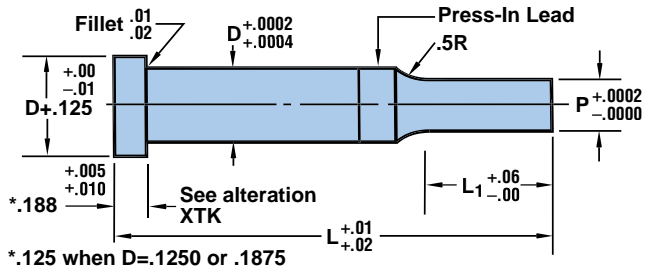

HOW TO ORDER

Specify:	Qty.	Type	D Code	Point Length L ₁	Overall Length L	P (or P&W) Dimension
Example:	2	VPXP	37	100	275	P.250
	1	VPJP	12	075	200	P.103,W.065



Round & Std. Shapes - 4 Days
 Classified Shapes - 5 Days

Shank D	Code	Point Lgth. L ₁	Round		Shape			L														
			Min. XP	Range P	Min. XW	Min. W	Max. P/G	1.50	1.75	2.00	2.25	2.50	2.75	3.00	3.25	3.50	3.75	4.00	4.25			
.1250	12	.50	.042	.062-.1249	.062	.062	.1250	050150														
.1875	18		.042	.062-.1874	.062	.062	.1875															
.2500	25		.062	.062-.2499	.062	.062	.2500															
.3125	31		.062	.093-.3124	.062	.093	.3125															
.3750	37		.062	.125-.3749	.080	.125	.3750															
.4375	43		.093	.187-.4374	.109	.187	.4375			050175	050200	050225	050250	050275	050300	050325	050350	050375	050400			
.5000	50		.125	.225-.4999	.125	.187	.5000															
.6250	62		.235	.310-.6249	.235	.250	.6250															
.7500	75		.300	.390-.7499	.235	.312	.7500															
.8750	87		.350	.440-.8749	.235	.343	.8750															
1.0000	100	.400	.485-.9999	.235	.375	1.0000																
.1250	12	.75	.058	.062-.1249	.062	.062	.1250															
.1875	18		.058	.062-.1874	.062	.062	.1875															
.2500	25		.062	.062-.2499	.062	.062	.2500															
.3125	31		.062	.093-.3124	.093	.093	.3125															
.3750	37		.062	.125-.3749	.109	.125	.3750															
.4375	43		.093	.187-.4374	.109	.187	.4375															
.5000	50		.125	.225-.4999	.125	.187	.5000															
.6250	62		.235	.310-.6249	.235	.250	.6250															
.7500	75		.300	.390-.7499	.235	.312	.7500															
.8750	87		.350	.440-.8749	.235	.343	.8750															
1.0000	100	.400	.485-.9999	.235	.375	1.0000																
.1250	12	1.00	.075	.093-.1249	.093	.093	.1250															
.1875	18		.075	.093-.1874	.093	.093	.1875															
.2500	25		.080	.093-.2499	.093	.093	.2500															
.3125	31		.093	.093-.3124	.093	.093	.3125															
.3750	37		.093	.125-.3749	.125	.125	.3750															
.4375	43		.093	.187-.4374	.141	.187	.4375															
.5000	50		.125	.225-.4999	.141	.187	.5000															
.6250	62		.235	.310-.6249	.235	.250	.6250															
.7500	75		.300	.390-.7499	.235	.312	.7500															
.8750	87		.350	.440-.8749	.235	.343	.8750															
1.0000	100	.400	.485-.9999	.235	.375	1.0000																
.1875	18	1.25	.093	.125-.1874	.125	.125	.1875															
.2500	25		.093	.125-.2499	.125	.125	.2500															
.3125	31		.093	.125-.3124	.125	.125	.3125															
.3750	37		.125	.125-.3749	.125	.125	.3750															
.4375	43		.125	.187-.4374	.172	.187	.4375															
.5000	50		.125	.225-.4999	.172	.187	.5000															
.6250	62		.235	.310-.6249	.235	.250	.6250															
.7500	75		.300	.390-.7499	.235	.312	.7500															
.8750	87		.350	.440-.8749	.235	.343	.8750															
1.0000	100		.400	.485-.9999	.235	.375	1.0000															

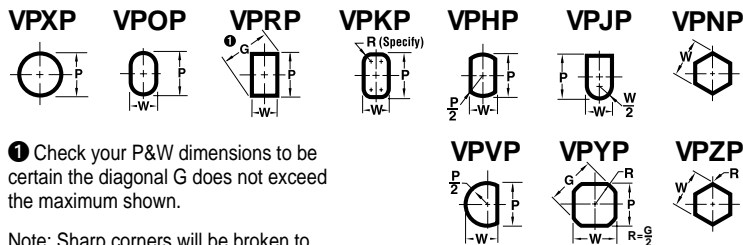

1 Check your P&W dimensions to be certain the diagonal G does not exceed the maximum shown.

Note: Sharp corners will be broken to minimize wear.

Note: The standard location of a key flat is at 0°. See p.17 for more information on flats and dowel slots.

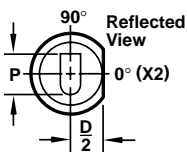

Code	L										
	4.50	4.75	5.00	5.25	5.50	5.75	6.00	6.25	6.50	6.75	7.00
12											
18											
25											
31											
37											
43	050450	050475	050500								
50				050525	050550	050575	050600				
62											
75											
87											
100											
12											
18											
25											
31											
37											
43	075450	075475	075500								
50				075525	075550	075575	075600				
62								075625	075650	075675	075700
75											
87											
100											
12											
18											
25											
31											
37											
43	100450	100475	100500								
50				100525	100550	100575	100600				
62								100625	100650	100675	100700
75											
87											
100											
18											
25											
31											
37											
43											
50	125450	125475	125500								
62				125525	125550	125575	125600				
75								125625	125650	125675	125700
87											
100											

Standard Alterations

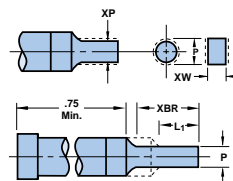

XP, XW P & W Dimensions Smaller than Standard

XBR Point Length Longer than Standard

Point Length	.000					.501-1.000					1.001-1.251				
	.500	.750	1.000	1.250	1.500	.000	.501-.750	.751-1.000	1.001-1.250	1.251-1.500	.000	.501-.750	.751-1.000	1.001-1.250	1.251-1.500
Code	Min. P (Rounds)					Min. W (Shapes)									
12	.042	.058	.075			.062	.062	.093							
18	.042	.058	.075	.093		.062	.062	.093	.125						
25	.062	.062	.080	.093		.062	.062	.093	.125						
31	.062	.062	.093	.093	.125	.062	.093	.093	.125	.125					
37	.062	.062	.093	.125	.125	.080	.109	.125	.125	.195					
43	.093	.093	.093	.125	.125	.109	.109	.141	.172	.195					
50	.125	.125	.125	.125	.125	.125	.125	.141	.172	.195					
62	.235	.235	.235	.235	.235	.235	.235	.235	.235	.235					
75	.300	.300	.300	.300	.300	.235	.235	.235	.235	.235					
87	.300	.300	.300	.300	.300	.235	.235	.235	.235	.235					
100	.400	.400	.400	.400	.400	.235	.235	.235	.235	.235					

XD Reduced Shank Diameter

Head diameter does not change with body diameter.

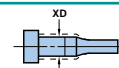

Shank Dia.	12	18	25	31	37	43	50	62	75	87	100
Min. XD	.063	.126	.188	.251	.313	.376	.438	.562	.688	.813	.938

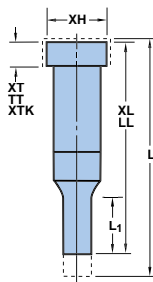

XL Overall Length Shortened (1.00 min.)

Stock removal from point end. L₁ length is maintained.

LL Precision Overall Length

Same as XL except overall length is held to ±.001.

XT Thinner Head than Standard

Stock removal from head end which shortens overall length.

TT Precision Head Thickness

Same as XT except head thickness tolerance is held to ±.0005.

XH Reduced Head Diameter

Minimum head diameter equals D +.000 - .001.

XTK Commercial Head Thickness

Shank Dia. D	12	18	25	31	37	43	50	62	75	87	100
Thickness T	.125	.125	.125	.125	.188	.188	.188	.250	.250	.250	.250

SBR Straight Before Radius

To determine Length of Radius Blend (LRB)

1. Calculate (D-P)/2.
2. Find (D-P)/2 value on left side of chart.
3. Follow line over to intersection point on radius blend line.
4. Read LRB value on bottom of chart.

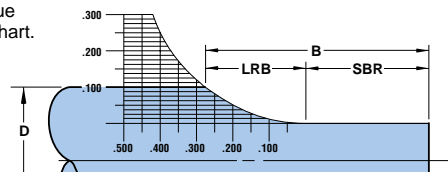

Example:

D=.375
P=.175
(D-P)/2=(.375-.175)/2=.100

Following the .100 line on chart over the radius blend line shows the LRB to be approximately .300.



Type
VPTP

Material

All heads are drawn to RC 40-55.
 Proprietary high-performance material and treatment
 P&W Tolerance $\begin{matrix} +.0002 \\ -.0000 \end{matrix}$ P to D $\begin{matrix} .0003 \\ \text{ } \end{matrix}$
 When P=D, shank tolerance applies.

HOW TO ORDER

Specify:	Qty.	Type	D Code	L	P Dimension
Example:	3	VPTP	37	100200	P.251
	2	VPTP	43	075250	P.300

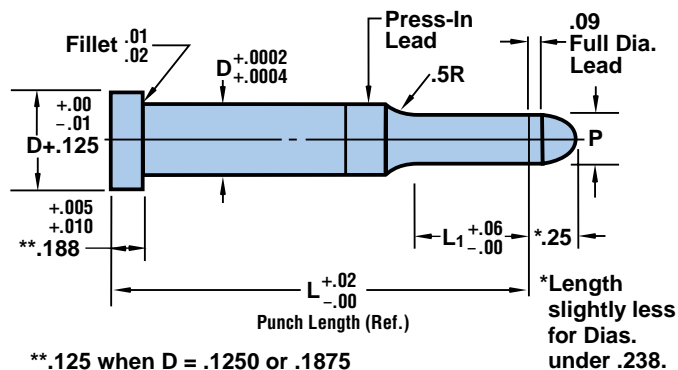

4 Days

Shank		Point Lgth. L1	Round		L													
D	Code		Min. XP	Range P	1.50	1.75	2.00	2.25	2.50	2.75	3.00	3.25	3.50	3.75	4.00	4.25	4.50	
.1250	12	.50	.050	.061 - .1250														
.1875	18		.050	.061 - .1875														
.2500	25		.061	.061 - .2500														
.3125	31		.061	.092 - .3125														
.3750	37		.061	.124 - .3750														
.4375	43		.092	.186 - .4375	050150	050175	050200	050225	050250	050275	050300	050325	050350	050375	050400			
.5000	50		.124	.224 - .5000														
.6250	62		.234	.309 - .6250												050425	050450	
.7500	75		.299	.389 - .7500														
.8750	87		.349	.439 - .8750														
1.0000	100	.399	.484 - 1.0000															
.1250	12	.75	.057	.061 - .1250														
.1875	18		.057	.061 - .1875														
.2500	25		.061	.061 - .2500														
.3125	31		.061	.092 - .3125														
.3750	37		.061	.124 - .3750														
.4375	43		.092	.186 - .4375		075175	075200	075225	075250	075275	075300	075325	075350	075375	075400			
.5000	50		.124	.224 - .5000														
.6250	62		.234	.309 - .6250														
.7500	75		.299	.389 - .7500														
.8750	87		.349	.439 - .8750														
1.0000	100	.399	.484 - 1.0000															
.1250	12	1.00	.074	.092 - .1250														
.1875	18		.074	.092 - .1875														
.2500	25		.079	.092 - .2500														
.3125	31		.092	.092 - .3125														
.3750	37		.092	.124 - .3750														
.4375	43		.092	.186 - .4375			100200	100225	100250	100275	100300	100325	100350	100375	100400			
.5000	50		.124	.224 - .5000														
.6250	62		.234	.309 - .6250														
.7500	75		.299	.389 - .7500														
.8750	87		.349	.439 - .8750														
1.0000	100	.399	.484 - 1.0000															
.1875	18	1.25	.092	.124 - .1875														
.2500	25		.092	.124 - .2500														
.3125	31		.092	.124 - .3125														
.3750	37		.124	.124 - .3750														
.4375	43		.124	.186 - .4375														
.5000	50		.124	.224 - .5000					125250	125275	125300	125325	125350	125375	125400	125425	125450	
.6250	62		.234	.309 - .6250														
.7500	75		.299	.389 - .7500														
.8750	87		.349	.439 - .8750														
1.0000	100		.399	.484 - 1.0000														

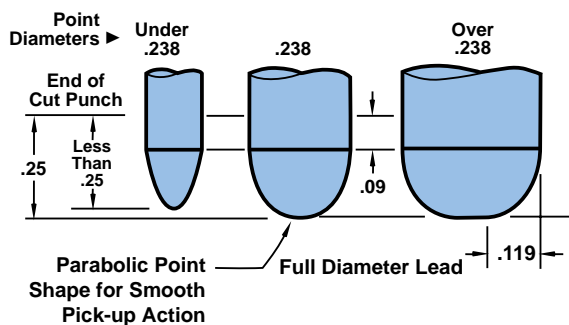

Standard Alterations

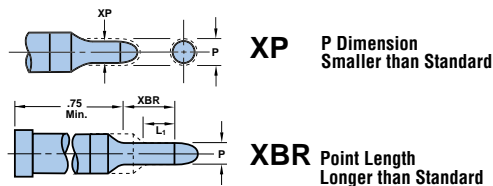

Point Length	XBR				
	.500-.750	.751-1.000	1.001-1.250	1.251-1.500	1.501-1.625
Code	Type	Min. P (Rounds)			
12	VPTP	.050	.057	.074	
18	VPTP	.050	.057	.074	.092
25	VPTP	.061	.061	.079	.092
31	VPTP	.061	.061	.092	.092 .124
37	VPTP	.061	.061	.092	.124 .124
43	VPTP	.092	.092	.092	.124 .124
50	VPTP	.124	.124	.124	.124 .124
62	VPTP	.234	.234	.234	.234 .234
75	VPTP	.299	.299	.299	.299 .299
87	VPTP	.349	.349	.349	.349 .349
100	VPTP	.399	.399	.399	.399 .399

Code	L									
	4.75	5.00	5.25	5.50	5.75	6.00	6.25	6.50	6.75	7.00
12										
18										
25										
31										
37										
43										
50	050475	050500								
62										
75										
87										
100										
12										
18										
25										
31										
37										
43										
50	075475	075500								
62										
75										
87										
100										
12										
18										
25										
31										
37										
43										
50	100475	100500								
62										
75										
87										
100										
18										
25										
31										
37										
43										
50	125475	125500								
62										
75										
87										
100										

XD Reduced Shank Diameter

Head diameter does not change with body diameter.

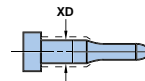

Shank Dia.	12	18	25	31	37	43	50	62	75	87	100
Min. XD	.063	.126	.188	.251	.313	.376	.438	.562	.688	.813	.938

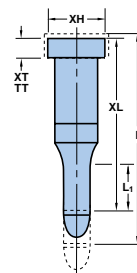

- XL Overall Length Shortened (1.00 min.)**
Stock removal from point end. L_1 is maintained.
- XT Thinner Head than Standard**
Stock removal from head end which shortens overall length.
- TT Precision Head Thickness**
Same as XT except head thickness tolerance is held to $\pm .0005$.
- XH Reduced Head Diameter**
Minimum head diameter equals $D + .000 - .001$.

XTK Kommercial Head Thickness

Shank Dia. D	12	18	25	31	37	43	50	62	75	87	100
Thickness T	.125	.125	.125	.125	.188	.188	.188	.250	.250	.250	.250

SBR Straight Before Radius (L_r)

To determine Length of Radius Blend (LRB)

1. Calculate $(D-P)/2$.
2. Find $(D-P)/2$ value on left side of chart.
3. Follow line over to intersection point on radius blend line.
4. Read LRB value on bottom of chart.

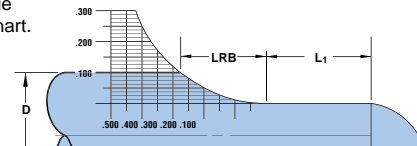

Example:

$D = .375$
 $P = .175$
 $(D-P)/2 = (.375 - .175)/2 = .100$
 Following the .100 line on chart over the radius blend line shows the LRB to be approximately .300.



Type
VPAP

Material

All heads are drawn to RC 40-55.
 Proprietary high-performance material and treatment
 P Tolerance $\begin{smallmatrix} +.0002 \\ -.0000 \end{smallmatrix}$ P to D $\begin{smallmatrix} .0003 \\ \text{Ⓢ} \end{smallmatrix}$
 When P=D, Tolerance is $\begin{smallmatrix} +.0002 \\ +.0004 \end{smallmatrix}$
 When P=D, shank tolerance applies.

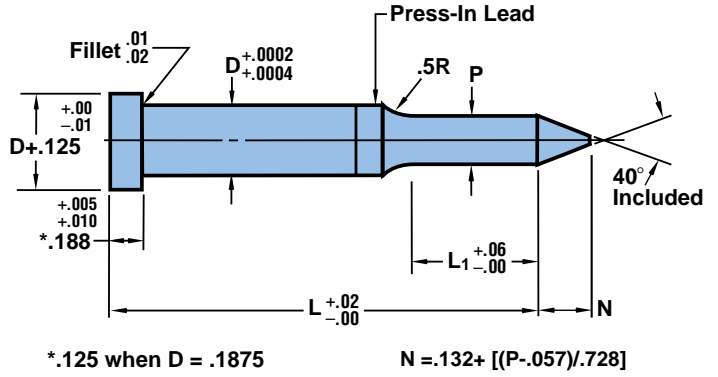

HOW TO ORDER

Specify: Qty. Type D Code L P Dimension
 Example: 6 VPAP 100 100400 P.749



Round		Point Lgth. L1	Round		Max. N	L											
D	Code		Min. XP	Range P		2.00	2.25	2.50	2.75	3.00	3.25	3.50	3.75	4.00	4.25	4.50	
.50		.1875	18	.050	.061 - .1875	.18											
		.2500	25	.061	.061 - .2500	.25											
		.3125	31	.061	.092 - .3125	.31											
		.3750	37	.061	.124 - .3750	.37											
		.4375	43	.092	.186 - .4375	.43	050200	050225	050250	050275	050300	050325	050350	050375	050400	050425	050450
		.5000	50	.124	.224 - .5000	.50											
		.6250	62	.234	.309 - .6250	.62											
		.7500	75	.299	.389 - .7500	.75											
		.8750	87	.349	.439 - .8750	.87											
		1.0000	100	.399	.484 - 1.0000	1.00											
.75		.1875	18	.057	.061 - .1875	.18											
		.2500	25	.061	.061 - .2500	.25											
		.3125	31	.061	.092 - .3125	.31											
		.3750	37	.061	.124 - .3750	.37											
		.4375	43	.092	.186 - .4375	.43	075200	075225	075250	075275	075300	075325	075350	075375	075400	075425	075450
		.5000	50	.124	.224 - .5000	.50											
		.6250	62	.234	.309 - .6250	.62											
		.7500	75	.299	.389 - .7500	.75											
		.8750	87	.349	.439 - .8750	.87											
		1.0000	100	.399	.484 - 1.0000	1.00											
1.00		.1875	18	.074	.092 - .1875	.18											
		.2500	25	.079	.092 - .2500	.25											
		.3125	31	.092	.092 - .3125	.31											
		.3750	37	.092	.124 - .3750	.37											
		.4375	43	.092	.186 - .4375	.43		100225	100250	100275	100300	100325	100350	100375	100400	100425	100450
		.5000	50	.124	.224 - .5000	.50											
		.6250	62	.234	.309 - .6250	.62											
		.7500	75	.299	.389 - .7500	.75											
		.8750	87	.349	.439 - .8750	.87											
		1.0000	100	.399	.484 - 1.0000	1.00											
1.25		.1875	18	.074	.092 - .1875	.18											
		.2500	25	.079	.092 - .2500	.25											
		.3125	31	.092	.092 - .3125	.31											
		.3750	37	.092	.124 - .3750	.37											
		.4375	43	.092	.186 - .4375	.43											
		.5000	50	.124	.224 - .5000	.50			125250	125275	125300	125325	125350	125375	125400	125425	125450
		.6250	62	.234	.309 - .6250	.62											
		.7500	75	.299	.389 - .7500	.75											
		.8750	87	.349	.439 - .8750	.87											
		1.0000	100	.399	.484 - 1.0000	1.00											

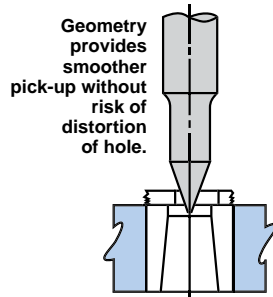
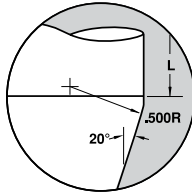

Greater positioning—
moves stock farther than
conventional pilots.

Standard Alterations

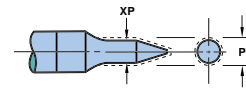

XP P Dimension
Smaller than Standard

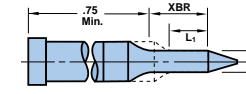

XBR Point Length Longer than Standard
Specify XBR, XBB, or X3B and length
(see chart below).

XBB and X3B add to delivery time.

Point Length	XBR										XBB	X3B	
	.500-.625	.626-.750	.751-.875	.876-1.000	1.001-1.125	1.126-1.250	1.251-1.375	1.376-1.500	1.501-1.625	1.626-2.000			2.001-2.501
Code	Type												
	Min. P (Rounds)												
18 VPAP	.050	.050	.057	.057	.074	.074	.092	.092					
25 VPAP	.061	.061	.061	.061	.079	.079	.092	.092					
31 VPAP	.061	.061	.061	.061	.092	.092	.092	.092	.124	.186			
37 VPAP	.061	.061	.061	.061	.092	.092	.124	.124	.124	.186	.249	.311	
43 VPAP	.092	.092	.092	.092	.092	.092	.124	.124	.124	.186	.249	.311	
50 VPAP	.124	.124	.124	.124	.124	.124	.124	.124	.124	.186	.249	.311	
62 VPAP	.234	.234	.234	.234	.234	.234	.234	.234	.234	.234	.311	.374	
75 VPAP	.299	.299	.299	.299	.299	.299	.299	.299	.299	.299	.299	.342	.405
87 VPAP	.349	.349	.349	.349	.349	.349	.349	.349	.349	.349	.349	.374	.420
100 VPAP	.399	.399	.399	.399	.399	.399	.399	.399	.399	.399	.399	.399	.436

XD Reduced Shank Diameter

Head Diameter does not change with body diameter.

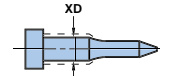

Shank Dia.	18	25	31	37	43	50	62	75	87	100
Min. XD	.126	.188	.251	.313	.376	.438	.562	.688	.813	.938

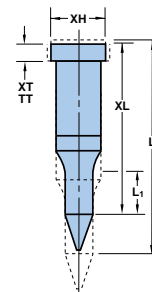

XL Overall Length Shortened (2.00 min.)
Stock removal from point end. L₁ is maintained.

XT Thinner Head than Standard
Stock removal from head end which shortens overall length.

TT Precision Head Thickness
Same as XT except head thickness tolerance is held to ±.0005.

XH Reduced Head Diameter
Minimum head diameter equals D +.000 - .001.

XTK Commercial Head Thickness

Shank Dia. D	18	25	31	37	43	50	62	75	87	100
Thickness T	.125	.125	.125	.188	.188	.188	.250	.250	.250	.250

SBR Straight Before Radius (L₁)

To determine Length of Radius Blend (LRB)

1. Calculate (D-P)/2.
2. Find (D-P)/2 value on left side of chart.
3. Follow line over to intersection point on radius blend line.
4. Read LRB value on bottom of chart.

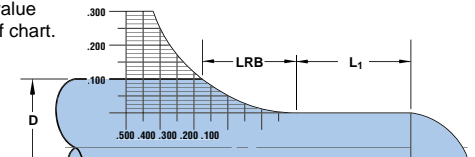

Example:

D=.375

P=.175

$(D-P)/2 = (.375 - .175)/2 = .100$

Following the .100 line on chart over the radius blend line shows the LRB to be approximately .300.

Code	L									
	4.75	5.00	5.25	5.50	5.75	6.00	6.25	6.50	6.75	7.00
18										
25										
31										
37										
43	050475	050500								
50			050525	050550	050575	050600				
62										
75										
87										
100										
18										
25										
31										
37										
43	075475	075500								
50			075525	075550	075575	075600				
62							075625	075650	075675	075700
75										
87										
100										
18										
25										
31										
37										
43	100475	100500								
50			100525	100550	100575	100600				
62										
75										
87										
100										
18										
25										
31										
37										
43	125475	125500								
50			125525	125550	125575	125600				
62										
75										
87										
100							125625	125650	125675	125700

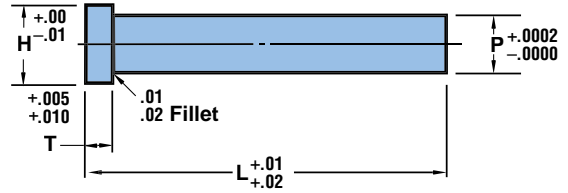
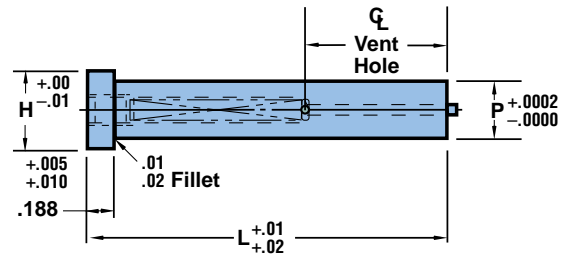

Material
 All heads are drawn to RC 40-55.
 Proprietary high-performance material and treatment
 P Tolerance $\begin{matrix} +.0002 \\ -.0000 \end{matrix}$

HOW TO ORDER

Specify:	Qty.	Type	Overall Length L	P Dimension
Example:	5	VYXP	250	P.324
	2	VUXP	325	P.492



Range P	Head Dia. H	Head Thk. T	Q Vent Hole	L																
				1.50	1.75	2.00	2.25	2.50	2.75	3.00	3.25	3.50	3.75	4.00	4.25	4.50				
VYXP	.1870-.2500	.375	See DWG.	.55	150	175	200	225	250	275	300									
	.2501-.3130	.438		.55	150	175														
	.3131-.3750	.500		.80		200	225	250	275	300	325	350	375	400						
				.60	150	175														
	.3751-.4380	.562		.85	150	175	200	225												
				1.10				250	275	300	325	350	375	400						
	.4381-.5000	.625		.85	150	175	200	225												
1.10						250	275	300	325	350	375	400								
.5001-.6250	.750		.85	150	175	200	225													
VUXP	.0620-.1250	.250	N/A	1.10					250	275	300	325	350	375	400					
	.1251-.1880	.312																		
	.1881-.2500	.375																		
	.2501-.3130	.438			150	175	200	225	250	275	300	325	350	375	400					
	.3131-.3750	.500																		
	.3751-.4380	.562																		
	.4381-.5000	.625																425	450	
.5001-.6250	.750																			

*See p. 18 for additional information.

VYXP



VUXP



Standard Alterations

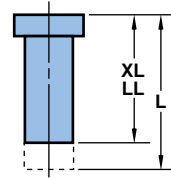

- XL Overall Length Shortened (1.00 min.)**
Stock removal from point end.
- LL Precision Overall Length**
Same as XL except overall length is held to ± 0.001 .

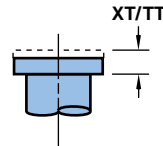

- XT Thinner Head than Standard**
Stock removal from head end which shortens overall length.
- TT Precision Head Thickness**
Same as XT except head thickness tolerance is held to ± 0.0005 .

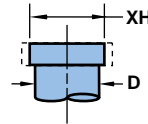

- XH Reduced Head Diameter**
Minimum head diameter equals $D + .000 - .001$.

L								* Jektole® Group
4.75	5.00	5.25	5.50	5.75	6.00	6.25	6.50	
								J2
								J3
								J4
								J6
								J6
								J9
475	500	525	550	575	600	625	650	N/A

The Dayton Difference

Since 1946, Dayton Progress has grown to an organization 1100+ people strong. We operate seven manufacturing/engineering facilities occupying a total of over 200,000 square feet (18,000 square meters) in North America, Europe, and the Pacific Rim. Further, we have alliances with selected manufacturers of leading-edge die component products that give us the ability to sell these proprietary products worldwide.

Our real strength, however, lies with our employees and business partners who bring years of experience and a wealth of talent. All of us in the Dayton "family" are dedicated to *creating value for our customers* because we care about quality, reliability, product performance, on-time delivery, technical support, and exceptional customer service.



Classified shapes are available on all punches, die buttons, and guide bushings in this catalog.

Ordering Information

*Corner Dimensions

Dimension should be the theoretical sharp corners for shapes C22, C24, C34, C61, and C88. However, some reduction of these dimensions will result from fitting the punch and die button under conditions where the clearance is .0025 or less per side.

Shape Center

Shapes are centered on the punch shanks as shown. Shapes in guide bushings and die buttons are also center as shown with the exception of shapes C22 and C34. Due to clearance, the P dimension on these shapes will not be centered.

Reflected View—Punches and Guides

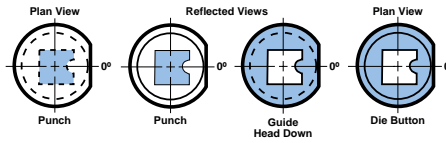

The reflected view is used for punches and guides. It is the view as seen in a mirror held below a punch or guide in its operating position. It is the same as a plan view from the head end, in which the point shapes is shown dotted. A reflected view is shown with solid lines.

Orientation and Locking

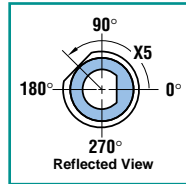

The locking device orientation is standard at 0°. For types of locking methods and custom locations, see p. 16.

Clearance

Normal grinding methods produce ① .007 max fillet on the punch and ② .007 max fillet on the die button with matching corner shape on the die button and punch, respectively. When ordering die buttons, please specify punch dimensions and clearance per side (Δ). (If the clearance is .0025 Δ , Dayton will break sharp corners when the punches and die buttons are ordered together.)

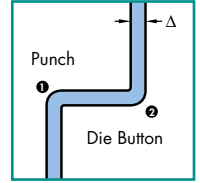

Sharp corners will be broken to minimize wear.

** Now standard. See product pages.

Flatted Rounds

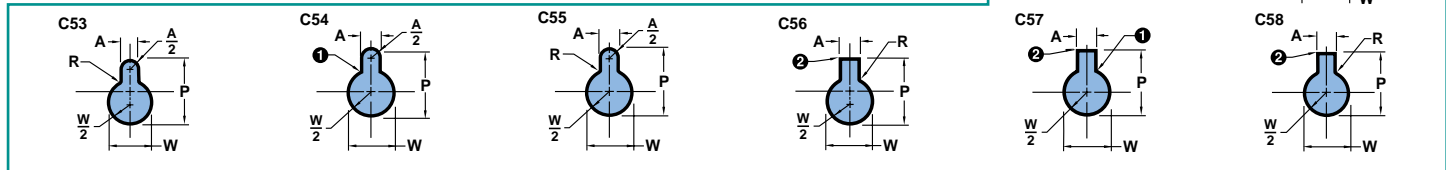
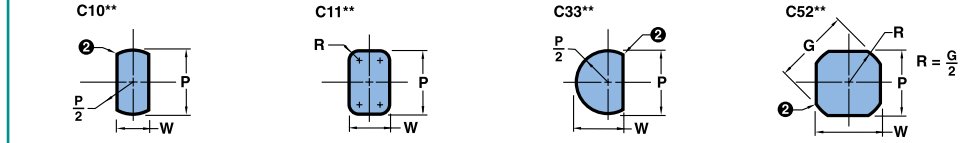

Mono Lobes

Miscellaneous

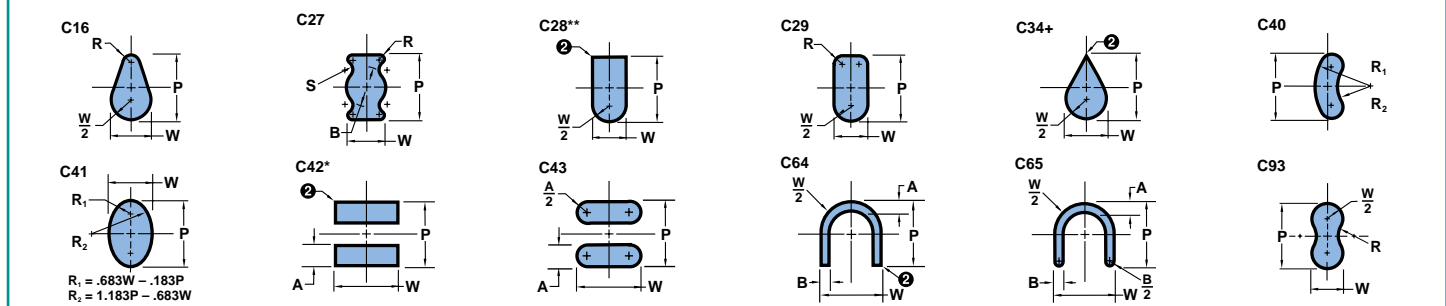

Triangles/Trapezoids

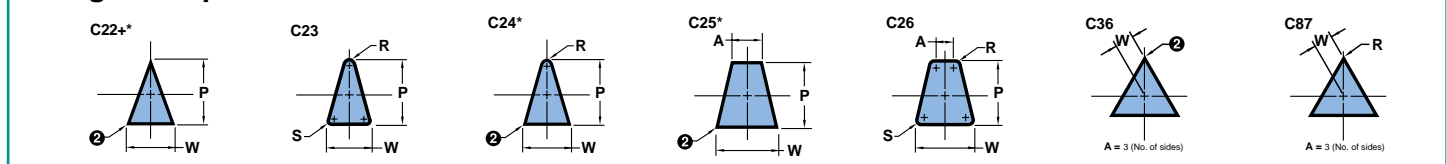

Multi Lobes



Polygons

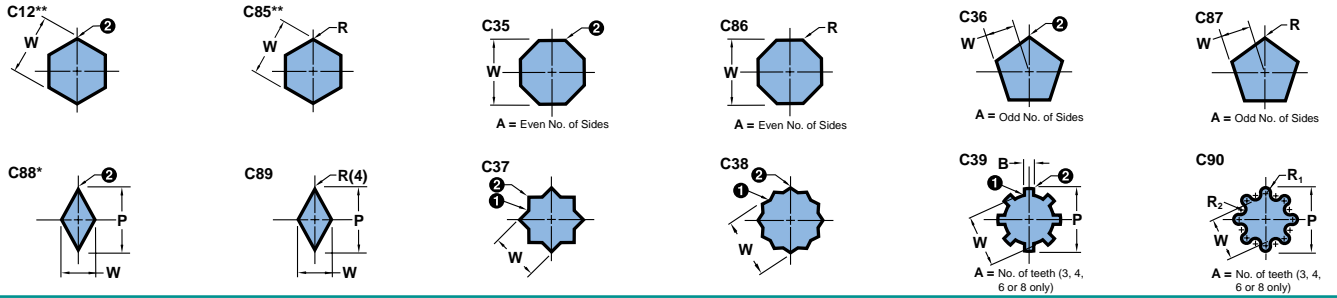

Keys

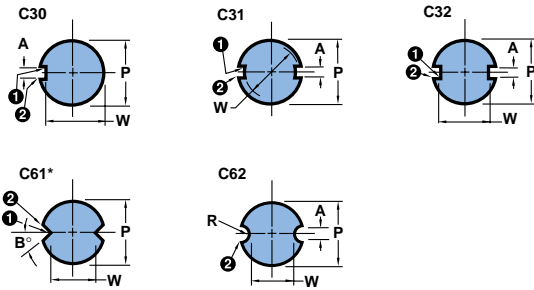

Duo Tees

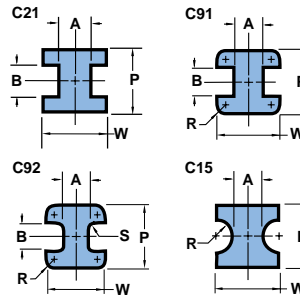

Ts

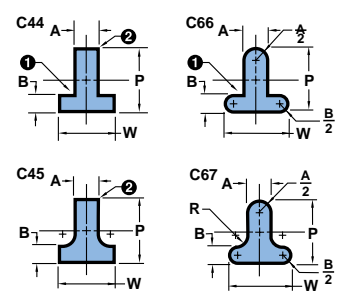

Ls

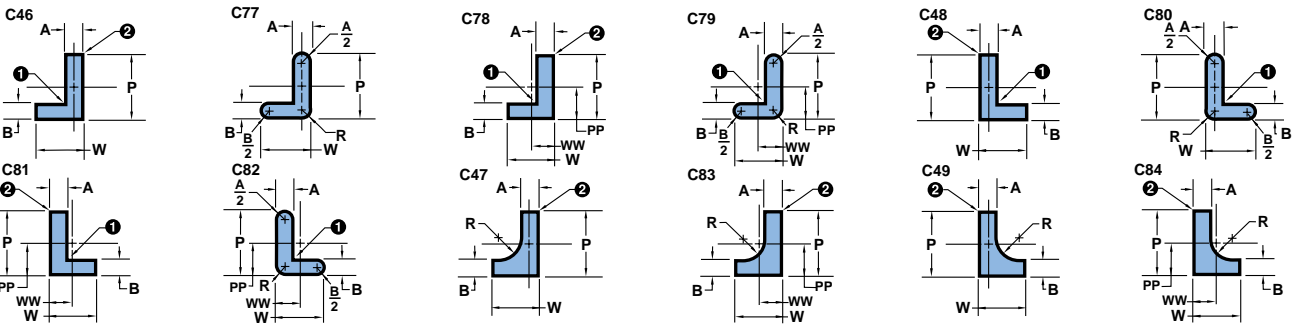

Us

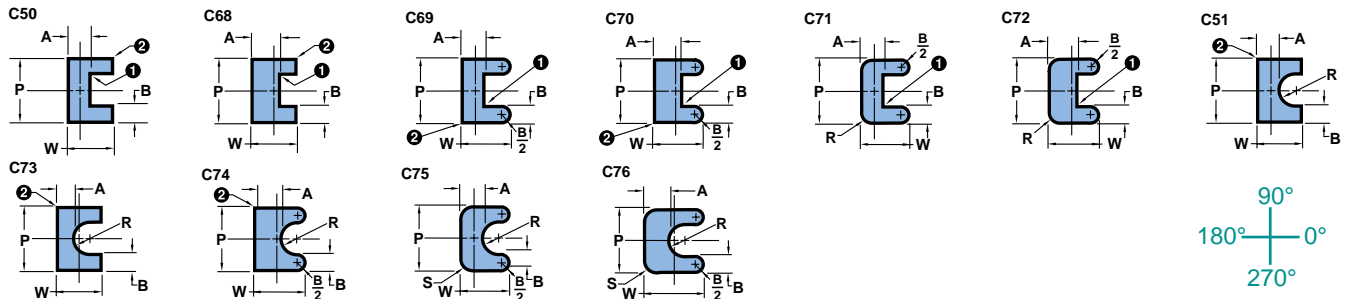

Orientation

The standard location for all locking devices is 0°, and is always on the long side (P) of the shape. Custom locations are measured counterclockwise from 0°. (See drawing below.)

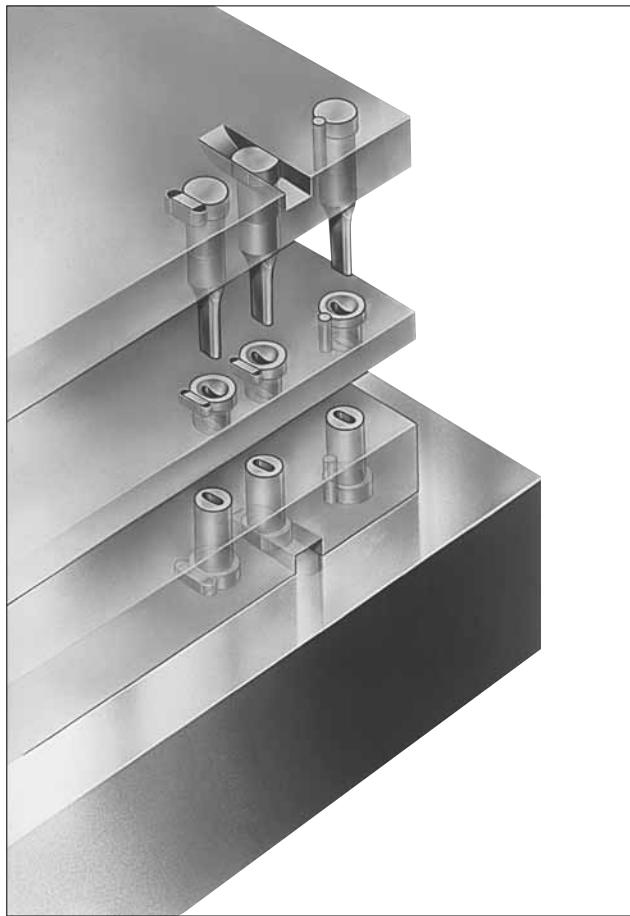
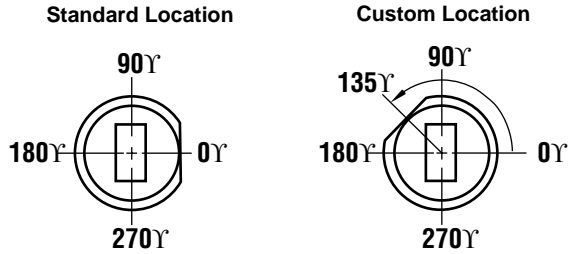

Views

A Plan View is used for the die button, and a Reflected View is used for the punch or guide. The Reflected View, a mirror image, simplifies orientation—locking devices are all in the same position.

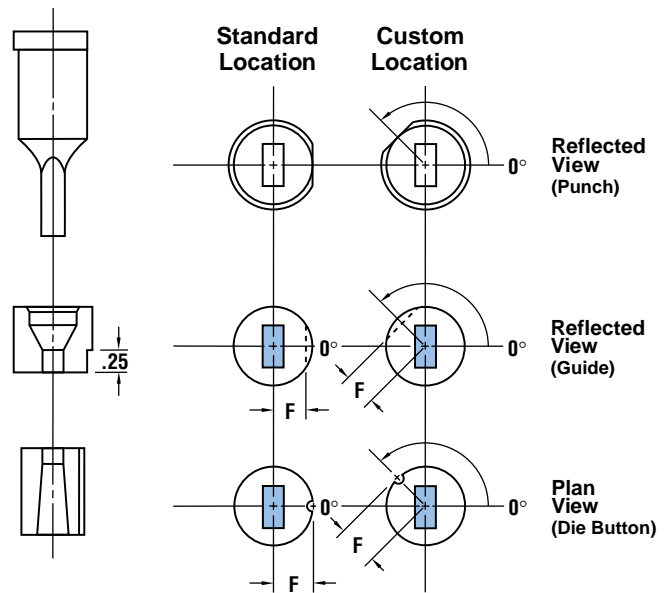
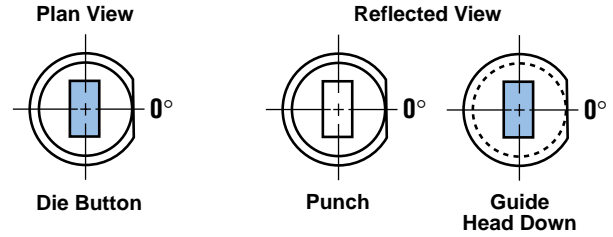

How To Specify

The most common locking devices—flat, double flat, and dowel—are available. Simply select the type, then add the code to the component description shown on p. 17.

HOW TO ORDER

Specify:	Qty.	Type	D	L ₁	L	P (or P&W) Dimension
Example:	1	VJJP	37	075	250	P.321, W.189

Location Tolerance

Flat		Dowel	
F	Radial	F	Radial
+ .0002	.0005/ inch	+ .0002	0°2'
- .0000		- .0000	

Flats vs. Dowel Slots



Flats

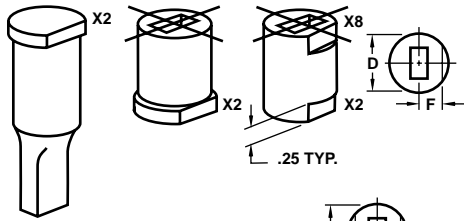

F Dimension
(.5D on Headed Products)
Headless Die Buttons and Guides

Body Dia.	18	25	31	37	43	50
F	.080	.110	.135	.165	.190	.220
Body Dia.	62	75	87	100	125	150
F	.270	.325	.380	.435	.540	.650
Body Dia.	175	200	225	250	275	
F	.775	.900	1.025	1.150	1.275	

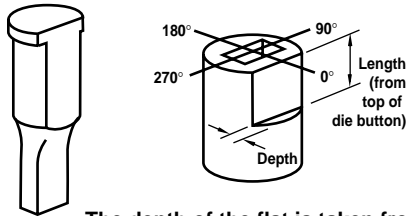

The depth of the flat is taken from the shank, not the head, on punches.

Key Flats vs. Dowel Slots

Maximum hole dimensions in die buttons were designed with key flats in mind. There are instances where, if using a dowel slot, the dowel hole could break into the relief. For this reason, there are two ways to specify the location of the dowel. **X0** (standard/alternate location) and **X1** (custom location) are located .5D from centerline. However, when hole dimensions are approaching the high limit of "P," **X4** (standard/alternate location) or **X7** (custom location) may be specified. This relocates the dowel outward to assure no interference between the dowel and the relief hole. Note: When the die button diameter is over .5000, the centerline dimension is .5D on all dowels.

Dowel Slots

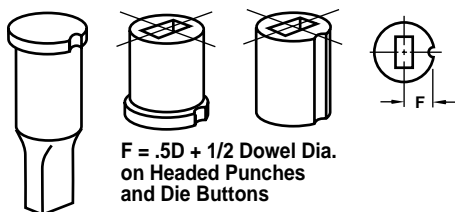

F = .5D + 1/2 Dowel Dia.
on Headed Punches
and Die Buttons

Standard and Alternate Locations

Definitions:
Standard Location is at 0°.
Alternate Location is 90°, 180°, or 270°.
Alternate Locations are available at no additional charge.

Single Flats

Locking Devices	Punches	Die Buttons
X2	Top	Bottom
X8	N/A	Top

Order Example:
X2 — 90°

Double Flats

Locking Devices	Punches	Die Buttons
X3	Top	Bottom

Order Example: X3 — 90°

Second Flat is *always parallel* to the first flat.

Additional Flats

Code	Depth	Length
X81*	.060	.500
X82*	.060	.625
X83*	.060	.750
X84	.060	Full Length
X85*	.093	.500
X86*	.093	.625
X87*	.093	.750
X88	.093	Full Length
X89	Specify Dimensions	

Dowel Slots

Locking Devices	Dowel Diameter
X0**	.1250
X4	.1250
X41	.1875
X43	.2500

Order Example: X0 — 180°

Custom Locations

Definitions:
Custom Location is *any angle other than*: 0°, 90°, 180°, or 270°.

Single Flats

Locking Devices	Punches	Die Buttons
X5	Top	Bottom
X9	N/A	Top

Order Example:
X5 — 135°

Double Flats

Locking Devices	Punches	Die Buttons
X6	Top	Bottom

Order Example: X6 — 135°

Additional Flats

Code	Depth	Length
X91*	.060	.500
X92*	.060	.625
X93*	.060	.750
X94	.060	Full Length
X95*	.093	.500
X96*	.093	.625
X97*	.093	.750
X98	.093	Full Length
X99	Specify Dimensions	

Dowel Slots

Locking Devices	Dowel Diameter
X1**	.1250
X7	.1250
X71	.1875
X73	.2500

Order Example: X71 — 135°

F Dimension for Headed Punches and Die Buttons

$F = .5D + .5 \text{ Dowel Dia.}$

F Dimension for Headless Die Buttons Only

Body Diameter		25	31	37	43	50	62	75	87	100	125-400
X0, X1	F	.1250	.1562	.1875	.2188	.2500	.5D	.5D	.5D	.5D	.5D
X4, X7		.1625	.1875	.2125	.2375	.2625	.5D	.5D	.5D	.5D	.5D
X41, X71		.1938	.2188	.2438	.2688	.2938	.5D	.5D	.5D	.5D	.5D
X43, X73		.2250	.2500	.2750	.3000	.3250	.3438	.4063	.4688	.5313	.5D

* not available on headed die buttons
** available on headless die buttons only





Jektol®
Cutaway

The Engineered Clearance

Perforating punch-to-button clearances in metal stamping dies has been universally expressed as a percentage of stock thickness, and for clarity should be articulated as percent per side (Δ =clearance per side).

Standard practice has called for Δ 5%, and is commonly known as “regular clearance.” Regular clearance has been applied almost universally to all applications involving the perforation of ferrous materials.

Jektol®, the **Engineered Clearance**, is approximately twice regular clearance, i.e., Δ 10-12%. This means greater productivity, improved maintenance, and a better return on your tooling investment.

In addition, clearances of up to Δ 50% are not uncommon with some hard materials. Clearance tests have been performed by Dayton Progress to prove that increasing the clearance does not lessen hole quality—a common thought by some designers and engineers. Dayton clearance tests do, in fact, prove that the Jektol® **Engineered Clearance** provides many advantages and benefits.

Jektol® In Production

- Requires less press tonnage
- Reduces the pressure required to strip the punch, which, in turn reduces punch wear
- Produces minimal burr
- Doubles—often triples—piece output per grind
- Reduces total punch costs

Jektol® In Maintenance

- Keeper Key holds pin in retracted position (see photo at left)
- Eliminates the need for disassembly before grinding
- Helps maintain proper pin extension
- Reduces downtime for regrinding

Standard Jektol® Data

DIMENSION	J2	J3	J4	J6	J9	
Std. Shank Diameter	D	.1875	.2500	.3125	.3750	.6250
					.4375	.7500
Point Hole Diameter	C	.020	.032	.046	.063	.094
Shank Hole Diameter	E	.086	.109	.141	.172	.221
Pin Extension		.03	.03	.06	.06	.06
Keeper Key Number		920045		920053		

Jektol® Design Limits

DIMENSION	J2	J3	J4	J6	J9	
Min. Shank Dia.	D	.172	.218	.282	.344	.442
Min. Point Dia.	P	.050	.080	.115	.158	.235
Max. Point Lgth.	L ₁	1.00	1.25	1.50	1.50	1.50

Jektol® Components

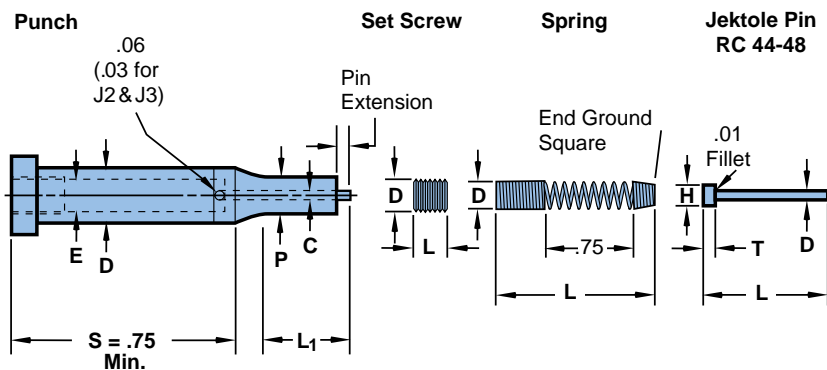

Universal Jektol® Components

EJECTOR PINS	J2	J3	J4	J6	J9	
Overall Length	L	1.11	1.38	1.94	1.94	2.22
Pin Diameter	D	.017	.027	.041	.058	.089
Head Diameter	H	.048	.073	.094	.120	.156
Hd. Thickness	T	.031	.047	.062	.062	.094
SPRINGS	J2	J3	J4	J6	J9	
Outside Dia.	D	.081	.104	.136	.167	.216
Free Length	L	2.38	2.38	3.19	3.00	3.03
Pressure (.12" Pre-load)	Lbs.	.5	.75	1	1.5	2
SCREWS	J2	J3	J4	J6	J9	
Screw Size	D	#3-48	#5-40	#8-32	#10-32	1/4-28
Screw Length	L	.19	.19	.19	.19	.25

VersaPlus® products are available in common shear angle configurations for all standard shapes.

Shear Angles can be applied to all punch points. These angles are used primarily to reduce slug pulling. Single and Double Shears can be used to reduce the punching force as well as minimize slug pulling. These alterations are prepriced and do not add to the standard delivery of the product.

Shear Angles are also available on Classified Shapes, but are available as special order only.

Standard head flat and dowel locations are at 0°.

Simply add the alteration code shown next to the drawings, and the angle desired, to your punch catalog number. Tolerance on all angles is ±15 minutes.

LL not available on XS19, XS21, XS22, and XS23.

Example: VJXP 37 075275 P.250 XS20 A5°.

For Round Punches Only

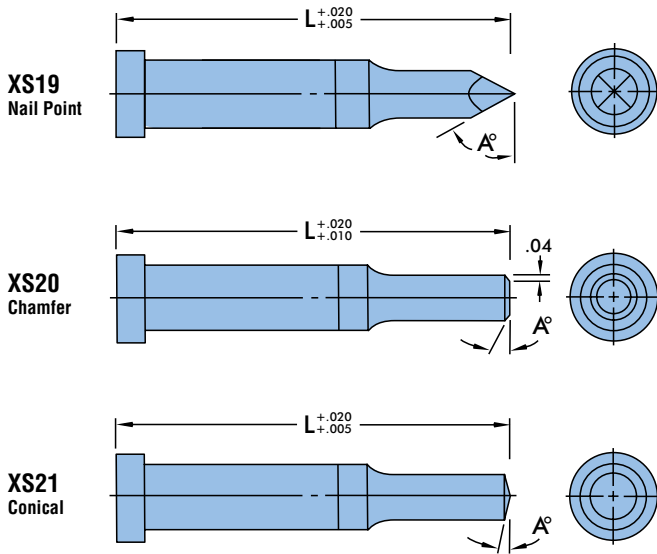

For Round and Shape Punches

Views are reflected view.

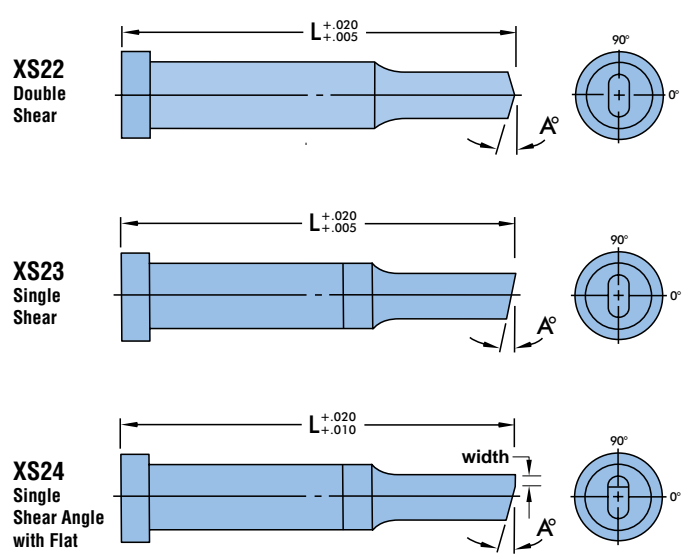

Commitment to Quality & Customer Satisfaction

Dayton Lamina is a leading manufacturer of tool, die and mold components for the metal-working and plastics industries. As a customer-focused, world-class supplier of choice, we provide the brands, product breadth, distribution network and technical support for all your metal forming needs.

Our goal is to give our customers the most innovative and value-added products and services.



DAYTON Lamina™

a MISUMI Group Company



Lamina® LEMPCO

*Dayton Lamina's line of Danly products is available only to North America.



SOCIO COMERCIAL EN MÉXICO

Oficina Matriz

Av. Regio Parque #200, Regio Parque Industrial,
Apodaca N.L. C.P. 66633



www.acatmexicana.com



acat@acatmexicana.com



TEL. 81 8354 8910